

## offset-printer

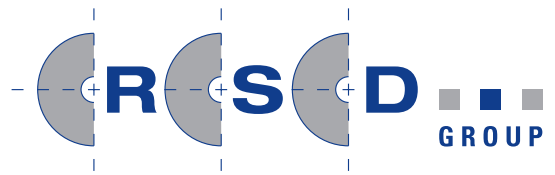

Type of machine	CP1Zi
Type of printing	offset printing
Drive	no
Automatic synchronization with line	no
Number of printing stations	1
Printing direction	l. → r. / r. → l.
Maximum printing diameter	Ø 0,8 mm - 55 mm (.031" - 2")
Lift column manual adjustable	yes
Print height adjustment	900 mm - 1200 mm (36" - 47")
Maximum printing speed without ink pump	150 m/min (490 fpm)
Maximum printing speed with ink pump	250 m/min (820 fpm)
Printing wheel diameter	Ø 80 mm
Mounting hole diameter	16 mm
Suitable for concave printing wheels	yes
Suitable for embossing/indenting wheels	yes
Printing simulator	no
Inline-stroboscope lamp(synchronized)	no
Viscosity control system	no
Viscosity unit for double ink pump system	no
Second ink pump unit for quick ink change	optional
Rail mounted	optional
Power supply pump	400 V, 50 Hz, 3 Ph
Weight machine + ink pump	approx. 40 kg + 23 kg (88 LBS + 51 LBS)

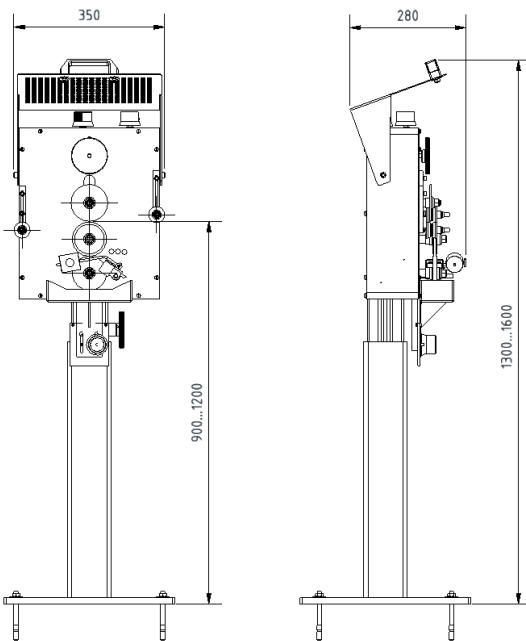

- traction-driven printing machine
- for printing on cables, hoses, tubes and tapes
- High-quality corrosion-resistant materials
- custom-made construction possible

